



RIFORMIMENTO
AUTO



FUEL MANAGEMENT
SYSTEMS



KITS



POMPE



CONTALITRI



PISTOLE
CONTALITRI

SUZZARABLU PUMP AC

CARATTERISTICHE

- PRONTO ALL'USO
- POMPA MULTIUSO
- AUTOADESCANTE
- VALVOLA BYPASS INCORPORATA

SUZZARABLU PUMP AC di PIUSI è la pompa a membrana più nota per l'AdBlue®. È dotata di un motore elettrico senza guarnizioni dinamiche. Questa soluzione permette di ottenere una pompa industriale affidabile con capacità autoadescente.

PERFORMANCE

FINO A

32 L/MIN

PORTATA

20 MIN

CICLO DI LAVORO



SUZZARABLU PUMP AC



Take care for the environment
with Li.Bo. Always.

www.libo.it/environment

un marchio di



PACKAGING

CODICE	PESO		PACKAGING		N. BOX/EUROPALLET	
	KG	LBS	MM	PEZZI/BOX		
F00203090	7	15,4	350X180X280	1	60	84



PISTOLE



FILTRAZIONE



MONITORAGGIO FLUIDI



ARROTOLATORI



ACCESSORI



MERCHANDISE

INDEX



ARIA



ANTIGELO



AdBlue®



BIODIESEL



DIESEL



ALIMENTI



BENZINA



GRASSO



KEROSENE



OLIO



ACQUA



LAVAVETRI

GRAFICO

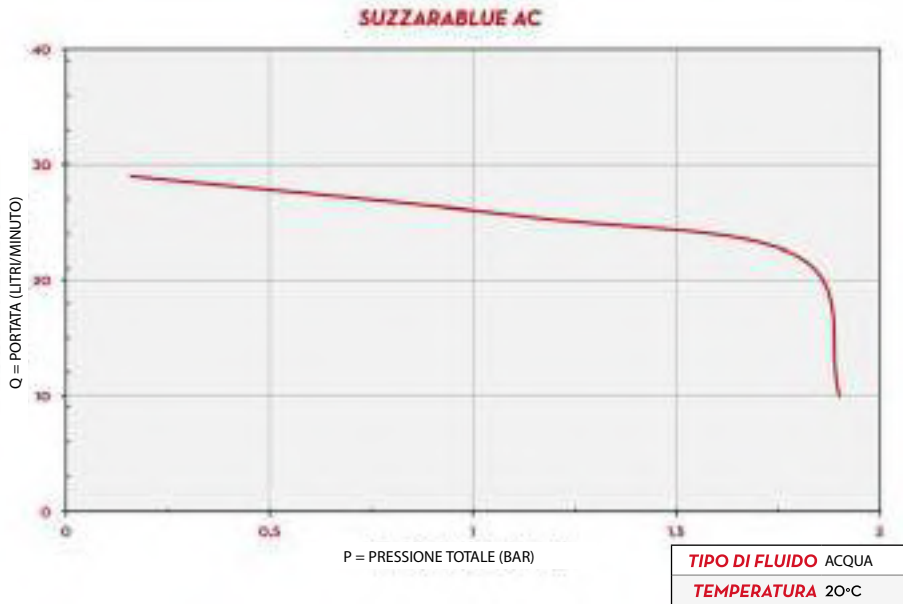

DENTRO LA SCATOLA

- SUZZARABLUÉ PUMP AC
- RACCORDI PER TUBO FLESSIBILE
- MANUALE ISTRUZIONI

DETTAGLI



ON/OFF INTERRUOTORE



PIASTRA DI FISSAGGIO

DIMENSIONI

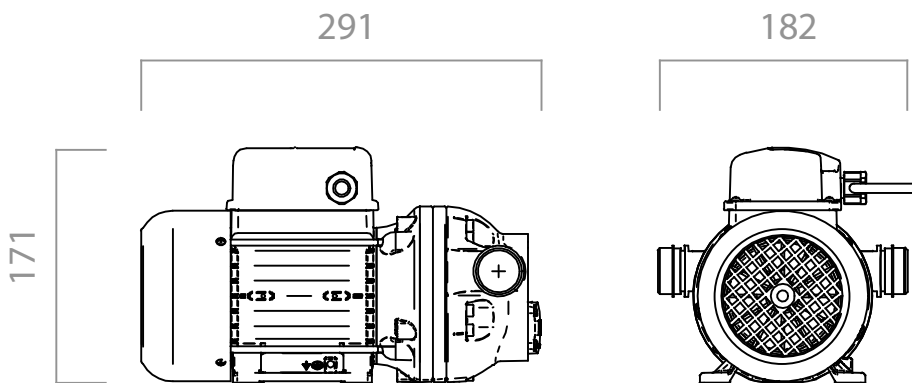

Dimensioni espresse in millimetri

MATERIALI

- CORPO: POLIPROPILENE
- MEMBRANA: POLIPROPILENE

Li.Bo
Environment

Take care for the environment
with Li.Bo. Always.

www.libo.it/environment

un marchio di

DATI TECNICI

CODICE	DESCRIZIONE	TIPI DI FLUIDO	PORTATA		VOLTAGGIO				CAVI	INLET-OUTLET	ON/OFF
			L/MIN	GPM	AC V/HZ DC VOLT	RPM	POTENZA WATT	AMP. MAX.	MOD.	BSP	INTERRUPTORE
F00203090	SUZZARABLUÉ AC PUMP 230/50	Ad W	32	8,5	230/50	1450	400	1,95	SI	3/4"	SI

A RICHIESTA È DISPONIBILE CON DIVERSI VOLTAGGI E FREQUENZE.

SUZZARABLUÉ PUMP AC

POMPE AC